



燕山大学  
YANSHAN UNIVERSITY

机械工程学院  
School of Mechanical Engineering

# 基于模型动态修正的液压泵剩余寿命预测方法

**Residual Useful Life Prediction Method for Hydraulic Pump  
Based on Dynamic Modified Model**

吴凤和

2023年2月19日



**目录**  
**Contents**

**1** **研究背景**  
Research background

**2** **液压泵耐久性试验台搭建及数据采集与处理**  
Hydraulic pump durability test bench construction and data acquisition and processing

**3** **剩余寿命预测原理及算法研究**  
Principle and algorithm of RUL

**4** **液压泵剩余寿命预测系统开发**  
Development of RUL prediction system

**5** **结论**  
Conclusions

# 1 研究背景 Research background

液压泵是液压系统的核心动力元件，汽轮机调节控制系统中大型液压泵的运维具有如下特点：

- **不允许计划外停机 No unplanned downtime**  
意外停机会导致整个调节控制系统的瘫痪；
- **计划性检修 Planned maintenance**  
防止突发性故障，预测结果必须“可靠、可信”；
- **维护成本高 High maintenance cost**  
剩余寿命利用率高；
- **寿命个体差异大 Individual differences in service life**  
缺乏先验样本的寿命预测不准确。

**退化指标的可解释性**  
Explainability of the degradation indicator

**退化模型的精确性**  
Accuracy of degenerate model

**预测结果的可靠性**  
Reliability of prediction results

需求

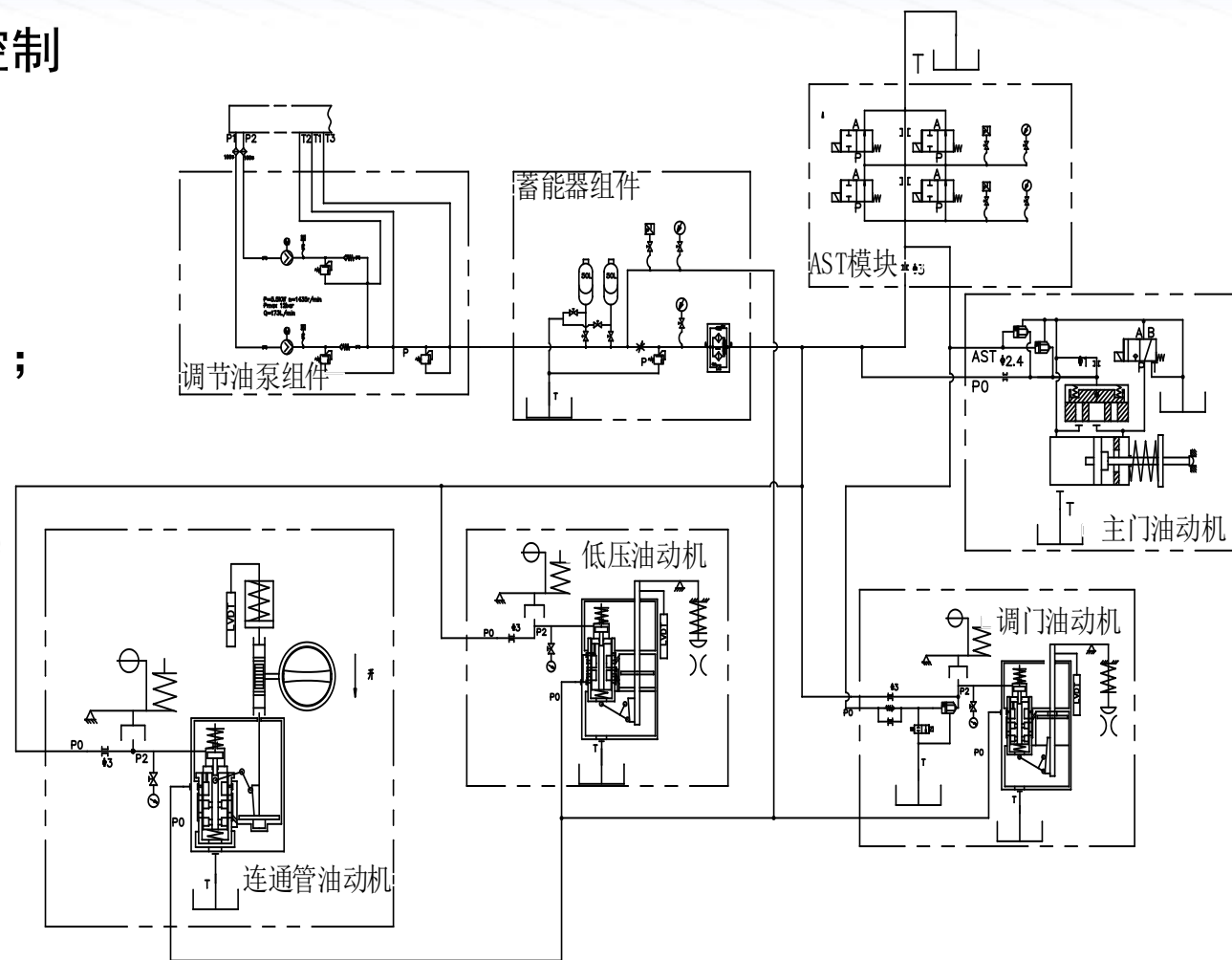

汽轮机调节系统原理图

Schematic diagram of turbine governing system

## ➤ 实测退化统计数据驱动的液压泵剩余寿命预测难点分析

### Difficulties analysis of RUL prediction for hydraulic pump based on measured degradation statistics

基于概率统计理论，通过**反映性能退化状态的监测数据**，建立液压泵性能演化过程的**退化模型**，揭示其性能退化的演变规律，并以概率分布的形式给出剩余寿命分布表达式，不仅能**得到剩余寿命的点估计**，而且还能**描述RUL预测的不确定性**。考虑长期累积损伤作用于当前实体，邻近当前时刻的数据价值远大于远离当前时刻的历史数据价值，因此需**对监测数据集的数据进行更新以动态修正退化模型及参数**。

The degradation model describing the performance evolution process of hydraulic pump is established through the monitoring degradation data, the performance degradation law is revealed, and the RUL is given in the form of probability distribution, which can not only obtain the point estimation, but also describe the uncertainty of RUL prediction. Besides, degradation model and parameters are dynamically modified by updating data.

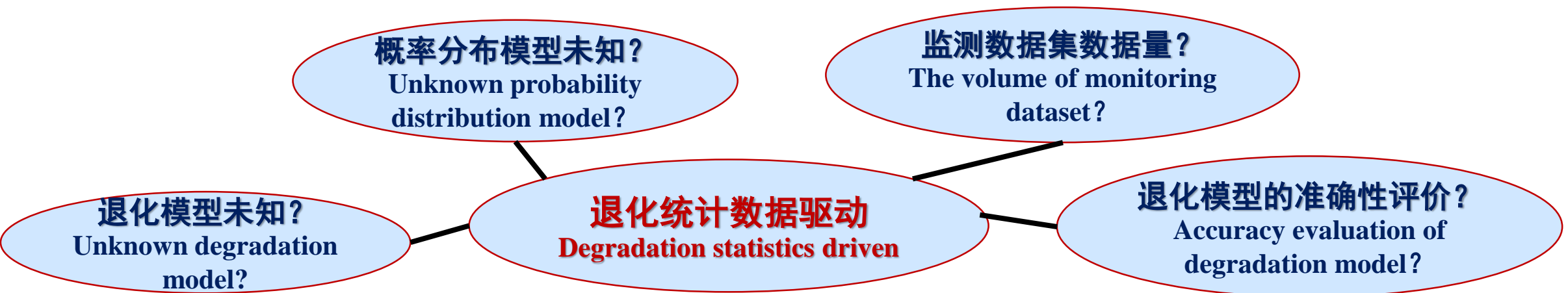



## 2 液压泵耐久性试验平台搭建及数据采集与处理 Test bench construction and data acquisition



燕山大学  
机械工程学院

### 2.1 液压泵耐久性试验平台搭建 Construction of hydraulic pump durability test platform

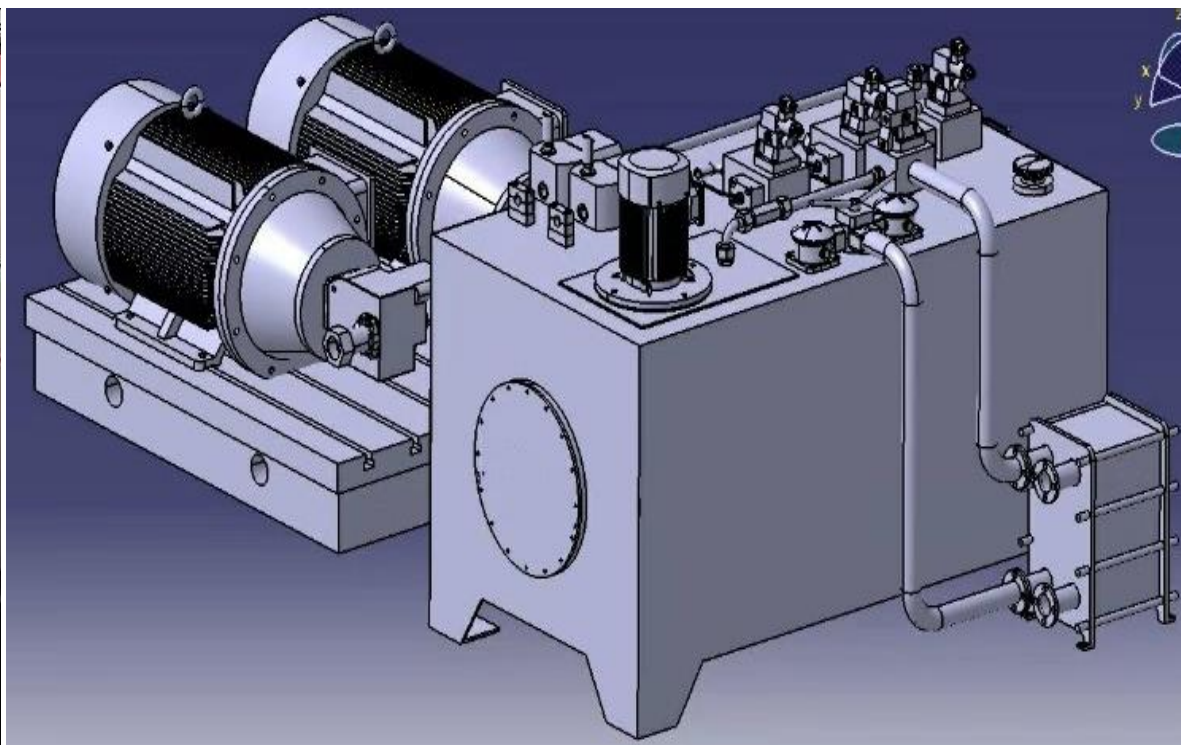
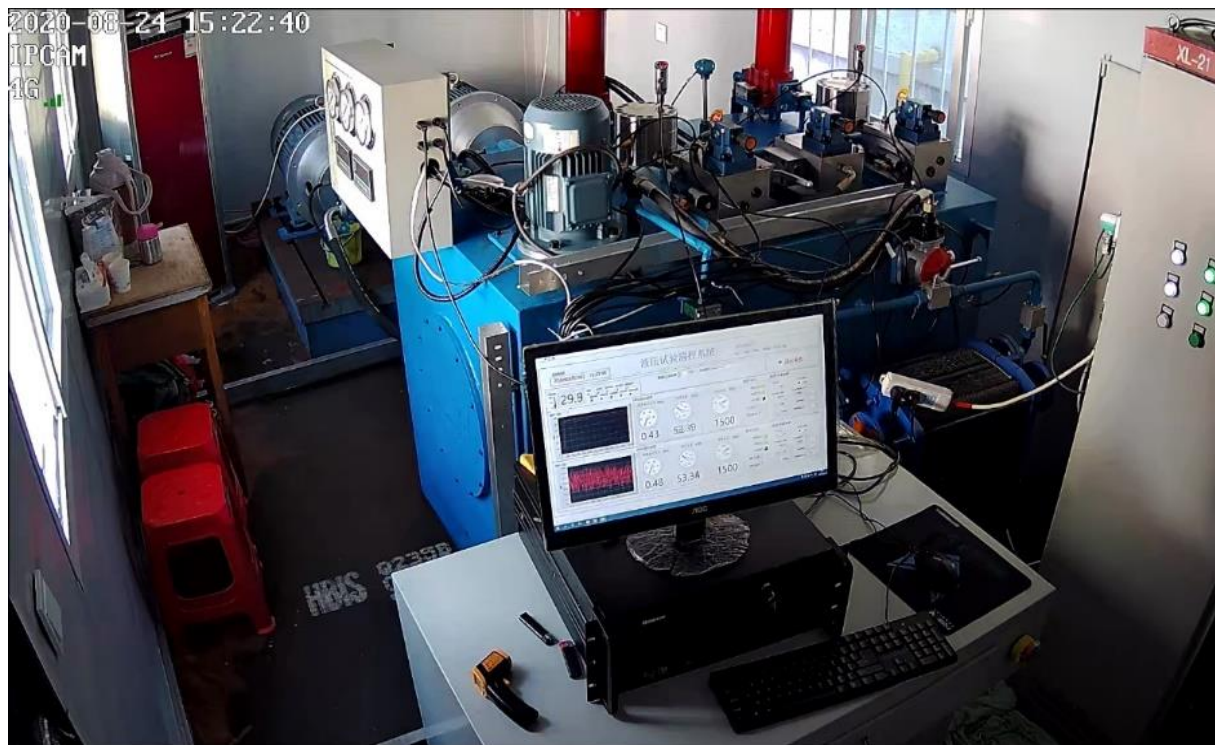

液压泵耐久性试验平台  
Hydraulic pump durability test platform

## 2 液压泵耐久性试验平台搭建及数据采集与处理 Test bench construction and data acquisition



### 2.2 数据采集与处理 Data acquisition and processing

通过液压泵的失效分析，确定以**容积效率**作为失效判据。

The volume efficiency is determined as the failure criterion through the failure analysis of hydraulic pump.

按照**JB/T7043-2006**中**6.2.2**、**6.2.13.2**，耐久性试验后，容积效率不应低于标准规定值的3个百分点，零件不得有异常磨损或其他形式的损坏，当**PVH74QIC-RSM-IS-10-C25-31斜盘式变量柱塞泵**容积效率下降至**88%**时，就判定其失效。



试验台以油源压力15MPa、50L/min的输出流量运行

The oil source pressure of the test bench operates at 15MPa working pressure and 50L/min output flow



液压数据采集系统

Hydraulic pump data acquisition system



## 3.1 剩余寿命预测原理 Principle of RUL prediction

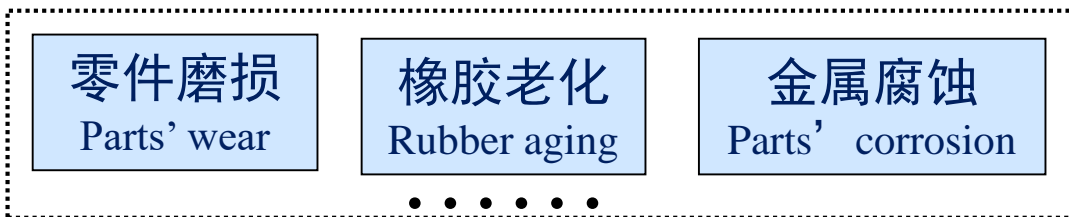

长期累积损伤导致剩余寿命存在长期累积效应，即**累积损伤已作用于当前时刻的物理实体**，导致历史无损伤的剩余寿命分布发生偏离，需要动态修正，其基本假设如下：

- **长期累积损伤**  
Long-term cumulative damage
- **当前时刻剩余寿命仅取决于前 $n$ 个时刻，而距离较远的历史数据则价值不大**  
The current RUL only depends on the previous  $n$  moments, while the historical data far away is of little value.

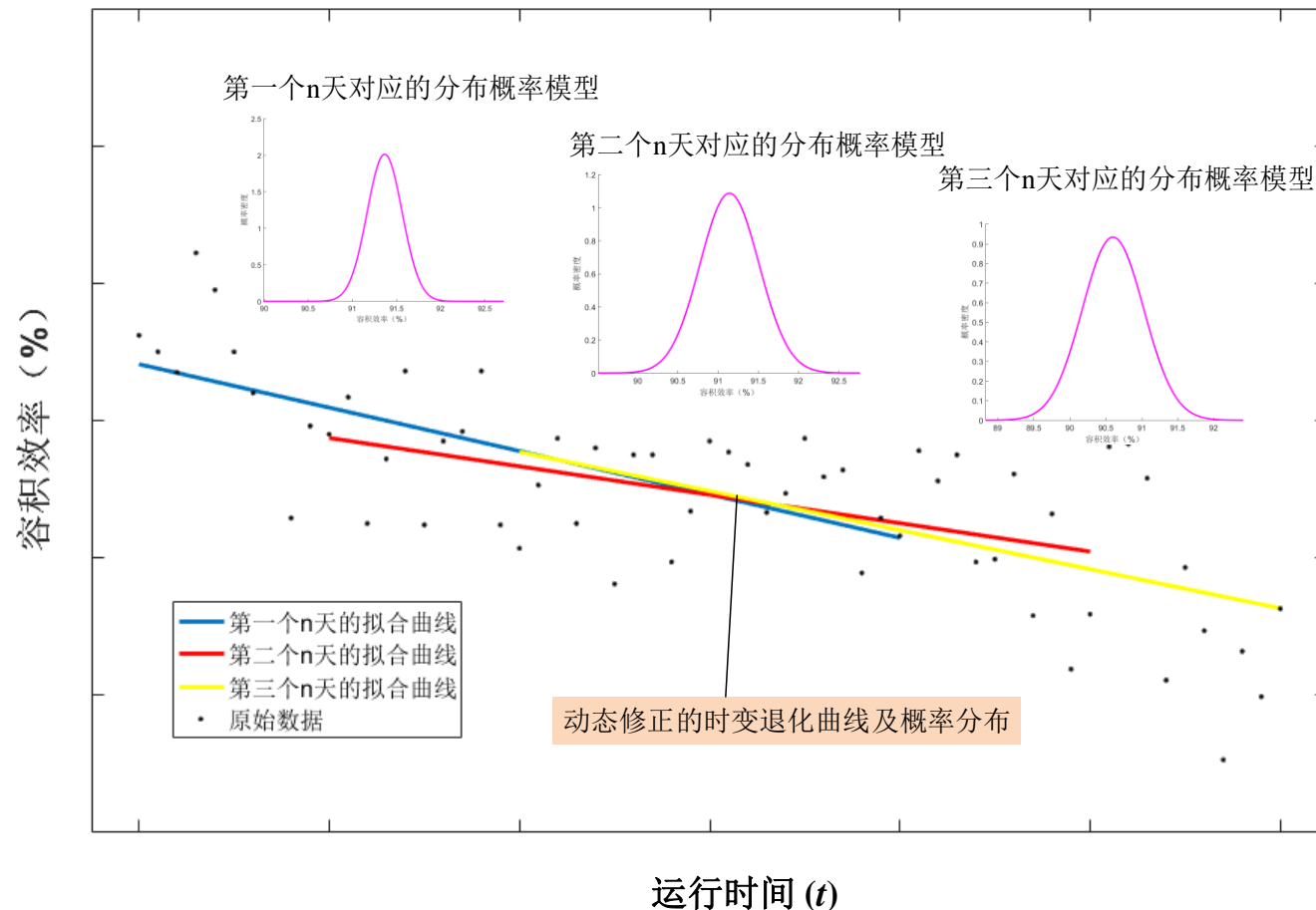







## 3.3 算法验证 Algorithm verification

用四组液压泵进行了对比实验，设定预测结果的可靠度为90%，对比结果显示，系统的准确性达87.3802%且稳定性较高，其准确性随着试验累计时间的增加而增加。

In addition, four groups of hydraulic pumps are also used for comparison experiments. The reliability probability of the prediction is set to 90%. The comparison results show that the accuracy of the system is 87.3802% and achieves the high stability. Its accuracy increases with the increase of test base impacts' number.

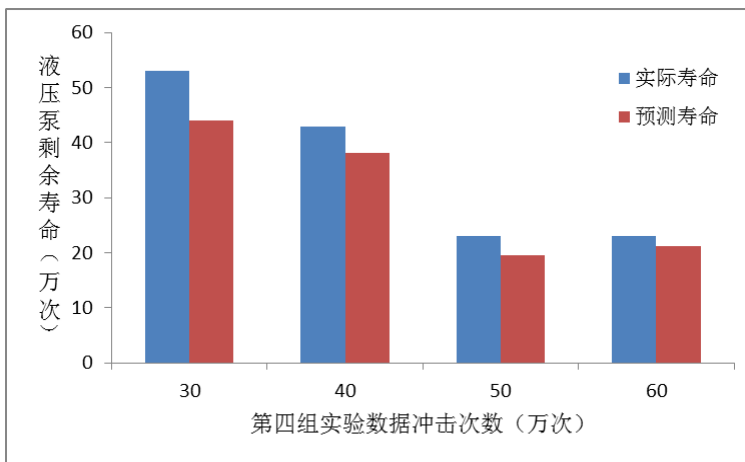
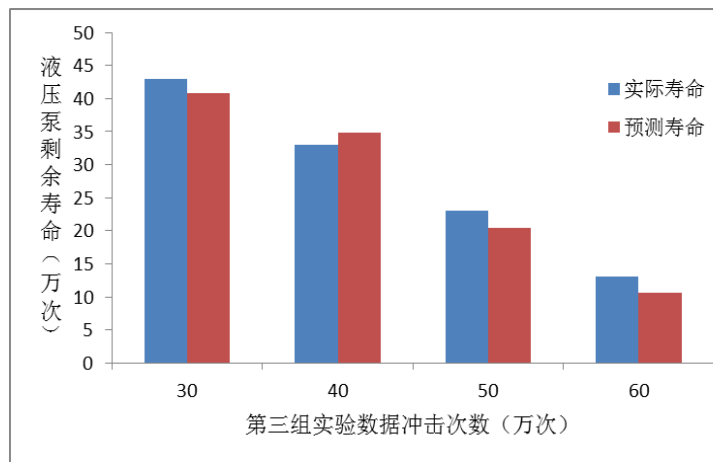
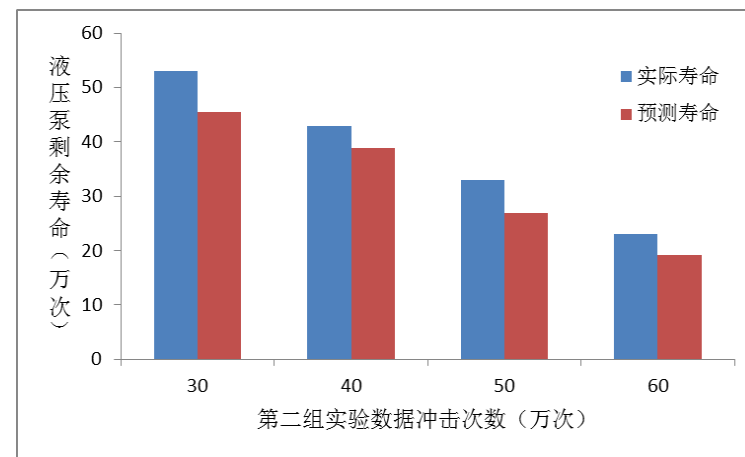
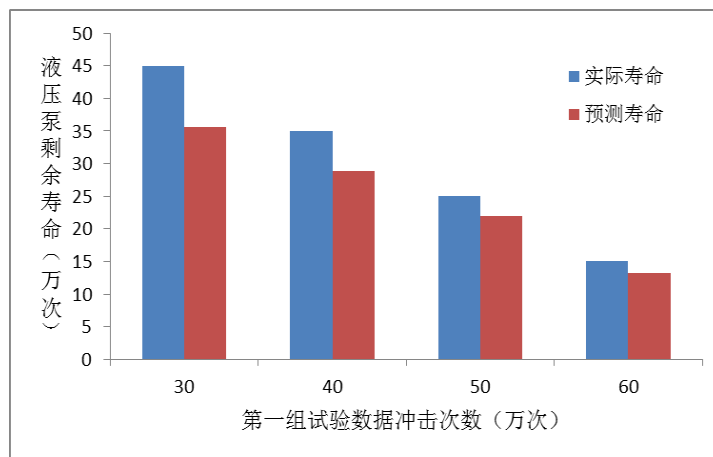

# 4 液压泵剩余寿命预测系统开发 Development of RUL prediction system



液压泵剩余寿命预测系统包括三个模块：**数据预处理**、**剩余寿命预测**、**历史数据查询**。

The RUL prediction system of hydraulic pump includes three modules: the data preprocessing module, the RUL prediction module and the historical data query module.

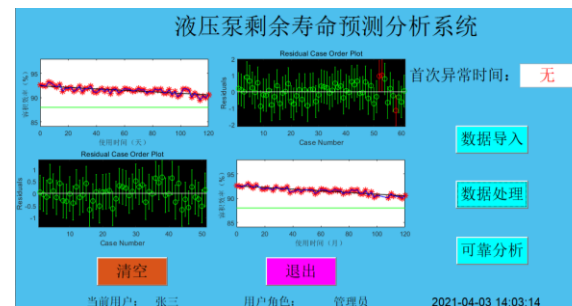

全日期查询				
序号	累计时间	可靠概率 (%)	可靠寿命	测试时间
1	120	90	116.0443	2021-03-24
2	120	85	121.2146	2021-03-24
3	120	80	125.2360	2021-03-24
4	120	70	131.5552	2021-03-24

剩余寿命预测系统

数据预处理模块

- 读取实时退化数据
- 计算并挖掘其退化规律
- 显示首次异常数据的时间

剩余寿命预测模块

- 退化建模
- 模型筛选及可靠概率输入
- 输出剩余使用寿命

历史数据查询模块

储存并查看历史记录

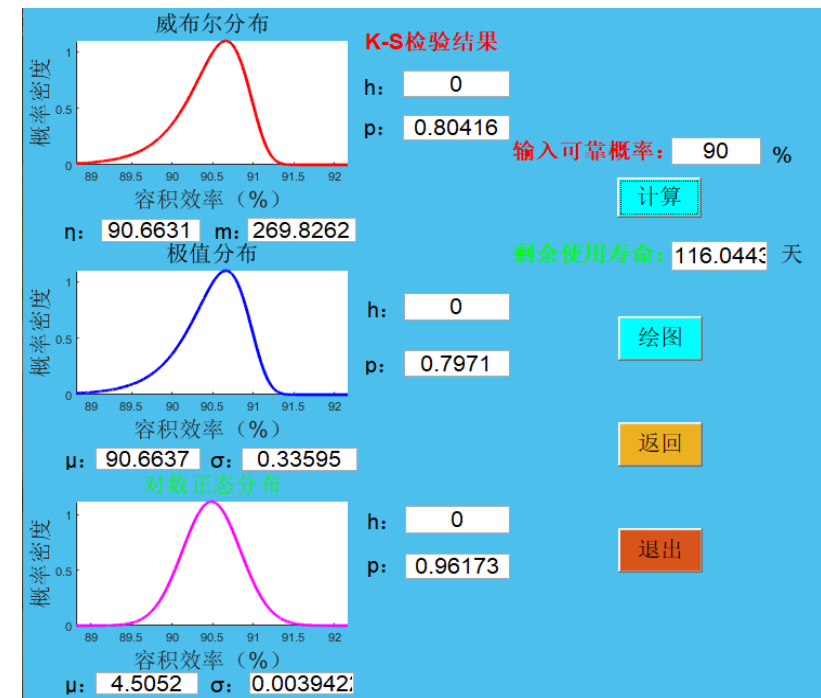

- **提出了一种基于模型动态修正的液压泵剩余寿命预测方法**，以拟合数值与实际数值的差值建立了液压泵可靠概率剩余寿命预测模型，获取了容积效率与其剩余寿命的映射关系，并**量化了预测结果的不确定性**。试验结果表明，该方法**预测精度达85%以上**。

A RUL prediction method of hydraulic pump based on dynamic modified model is proposed, and the reliability probability RUL prediction model of hydraulic pump is established based on the difference between the fitting value and the actual value. The mapping relationship between the volumetric efficiency and the RUL is obtained, and the uncertainty of the prediction result is quantified. The experimental results show that the prediction accuracy of the method is more than 85%.

- **开发了液压泵剩余寿命预测系统**，实现了数据导入及预处理、曲线拟合、残差分析、可靠性建模、K-S检验、剩余寿命预测、历史数据查看等功能，将预测结果与实际结果对比，验证了系统的准确性。

The RUL prediction system of hydraulic pump is developed, and the functions of data import and preprocessing, curve fitting, residual analysis, reliability modeling, K-S test, RUL prediction, and historical data viewing are realized. The accuracy of the system is verified by comparing the prediction results with the actual results.





燕山大学  
机械工程学院



Thanks!